



PRODUCT DATA SHEET

COMPLETE FUEL SYSTEM CLEANER + GAS TREATMENT PERFORMANCE BOOSTER

Rislone® Hy-per Fuel™ Complete Fuel System Cleaner + Gas Treatment / Performance Booster improves the quality of gas by increasing its cleaning ability, adding lubrication, removing contaminants, reducing spark knock, and helping to prevent the fuel from going bad. This one dual cavity bottle contains the same amount of additives equal to a bottle of regular injector & complete fuel system cleaner, upper cylinder lubricant, fuel stabilizer & conditioner, dry gas, gas treatment and octane booster. Simply put, it is the best all in one gasoline fuel additive money can buy. Works with ALL: Fuel Injected, Port Fuel Injection (PFI), Direct Injected (DI / DIG), Gasoline Turbo Direct Injected (GTDI), Turbocharged and Carbureted Engines. Use with ALL: Unleaded, Premium, and Ethanol (E10, E15, E85) Flex Fuel Vehicles

- Cleans Harmful Deposits from Injectors, Valves, Fuel Lines, Intake Manifold and the Combustion Chambers
- Restores Lost Power, Torque, Performance & Acceleration
- Maximizes Drivability, MPG, Lubrication & Fuel Economy
- Boosts Octane, Stabilizes Gas, Lubricates and Protects
- One Tank Deep Clean Fuel System Tune-Up
- Cleaning and Protecting Engines Since 1921
- Premium P.E.A. Polyetheramine New Generation Detergent Patented Formula is a multifunctional additive improving the quality of gasoline. Dual clean-up and keep-clean formula removes injector, combustion chamber and intake valve deposit which restores lost power and improves fuel economy.

1 Hy-per Fuel Treatment = 8 Regular Fuel Additives



100% SATISFACTION GUARANTEE:
 If you are not completely satisfied with the performance of our product, we will refund the purchase price. Visit www.rislone.com/refunds for details.

PRODUCT DATA SHEET

COMPLETE FUEL SYSTEM CLEANER + GAS TREATMENT PERFORMANCE BOOSTER

Technical:

- Upper Cylinder Lubricant (UCL) Top-Lube reduces friction and wear and improves fuel economy.
- Water Remover Gas Dryer removes free water in gas tank helping to prevent gas line freeze-ups in the winter, and moisture related corrosion year round. This also works to reduce emissions and inhibits bacterial growth in gas tanks.
- Fuel Stabilizer and Triple Corrosion Protection inhibits oxidation, gum, varnish and corrosion, helping gasoline resist breakdown improving stability. Provides A -rating corrosion protection.
- Gas Treatment Additives provide maximized power and acceleration, optimized fuel economy and excellent performance in gasoline engines.
- Octane Booster raises the Octane number of gasoline and Octane Requirement Increase (ORI) reduces spark knock, misfires and emissions.
- Increases power, performance, mileage and saves gas by cleaning & lubricating the complete fuel system. Engine dynamometer tests show improved fuel economy.
- Helps eliminate noisy injectors & fuel pumps, rough idle, hard starting and hesitation. Regular use provides reduced fuel system and emission control repairs.
- Will not void manufacture's new vehicle warranty and safe to use on vehicles which have oxygen sensors and catalytic converters. Exceeds EPA compliance performance criteria and is EPA registered.

Note:

This product includes a specially designed patented spout which allows it to be poured into all gas tanks, including those that use a capless (no fuel cap) system. Use anytime in a nearly full tank, or add to tank and then fill with up to 20 gallons of gas. For smaller tanks from 5 to 10 gallons, use 1/2 bottle pouring equal amounts from each side. Larger tanks use one bottle for every 16 gallons of gasoline.

Directions:

Bend & twist spout and tear away on the perforated tab. Remove cap and foil seal. Tightly screw spout onto bottle. (Pictured right) Gently tip bottle and complete insert spout into gas tank opening, allow entire contents to empty into tank. For continued protection and cleaning, use one bottle every 5,000 miles. Results will either be immediate, or noticeable within 100 miles of driving.

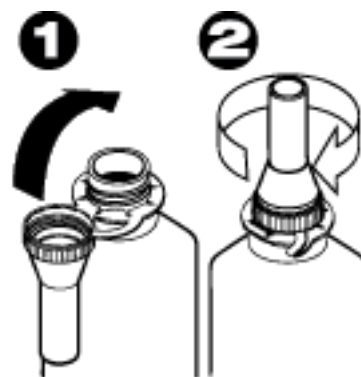

RISLONE

10386 North Holly Road
Holly, MI 48442 USA
www.rislone.com



GAS COMPLETE FUEL SYSTEM CLEANER

Part #: 4700

16.9 FL OZ (500 mL)